

CSCI 210: Computer Architecture

Lecture 29: More Pipelining

Stephen Checkoway

Oberlin College

Dec. 15, 2021

Slides from Cynthia Taylor

Announcements

- Problem Set 9 due Friday
- Lab 8 due Sunday, January 2, 2022
- Office hours Friday 13:30–14:30

MIPS Pipeline

Five stages, one step per stage, one clock cycle per stage

1. IF: Instruction fetch from memory
2. ID: Instruction decode & register read
3. EX: Execute operation or calculate address
4. MEM: Access memory operand
5. WB: Write result back to register

Execution in a Pipelined Datapath

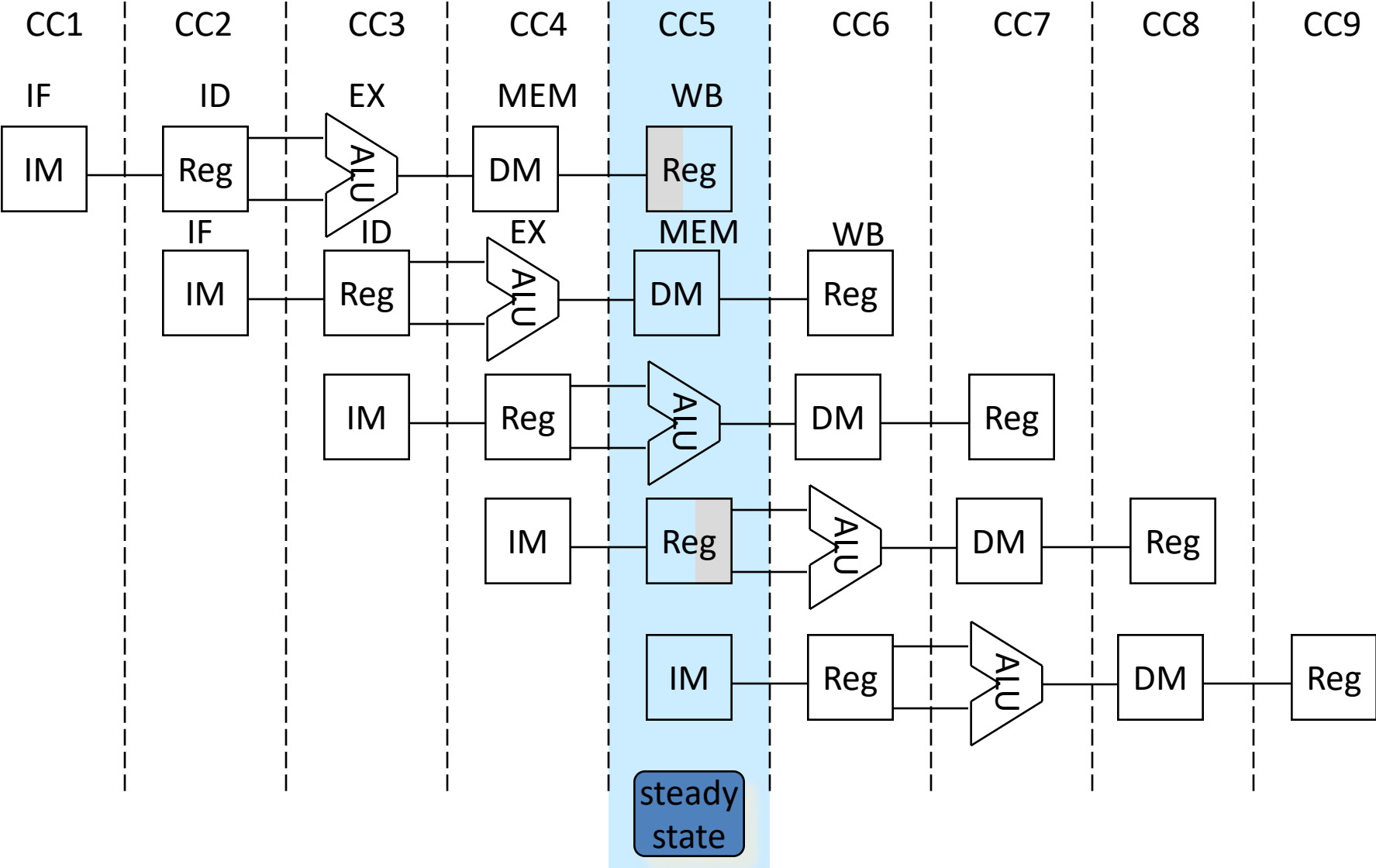

We can perform a register read and a register write in the same cycle. Which should we do first?

A. Read

B. Write

C. It doesn't matter

Single Cycle Datapath

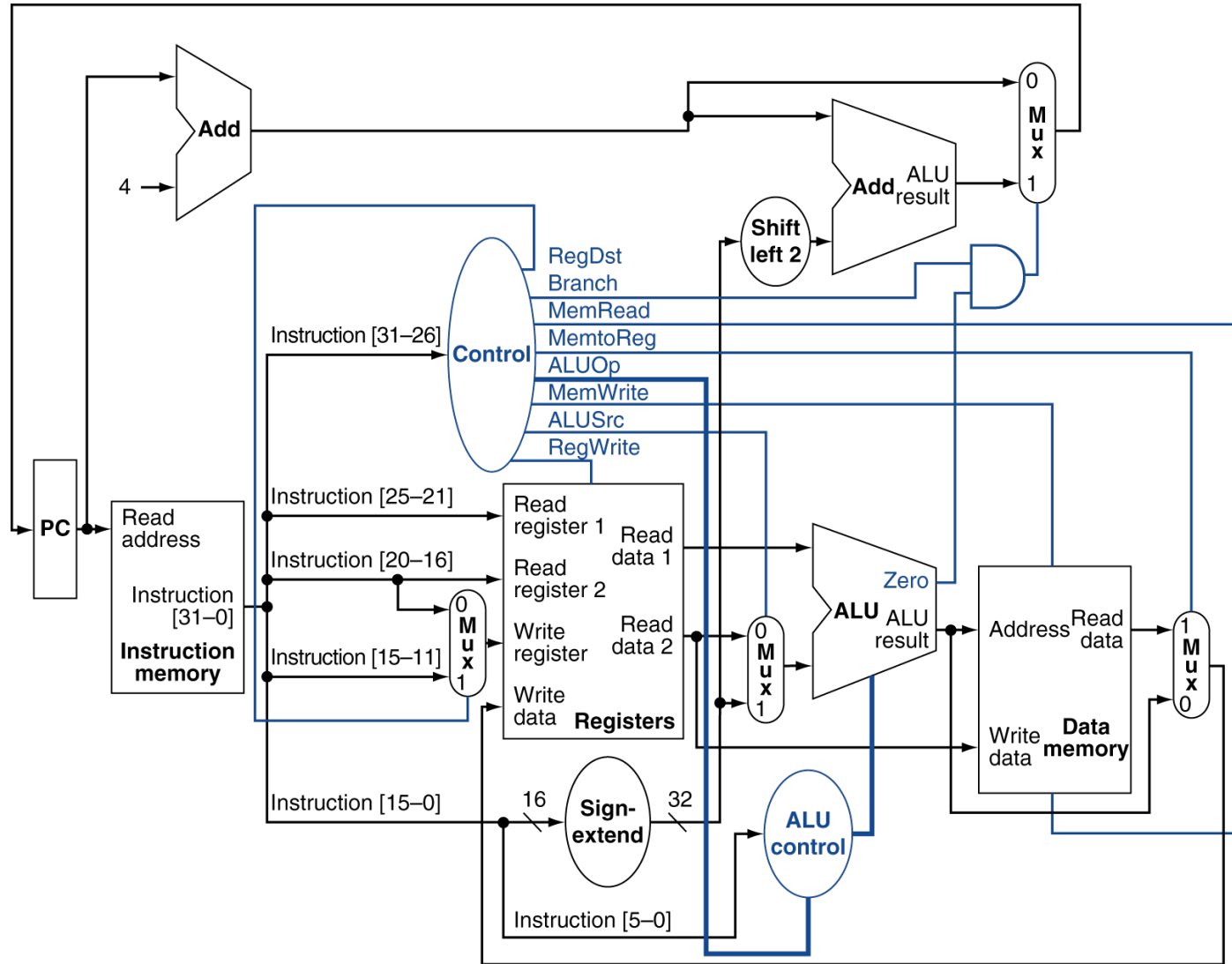

Pipeline registers

- Need registers between stages
 - To hold information produced in previous cycle

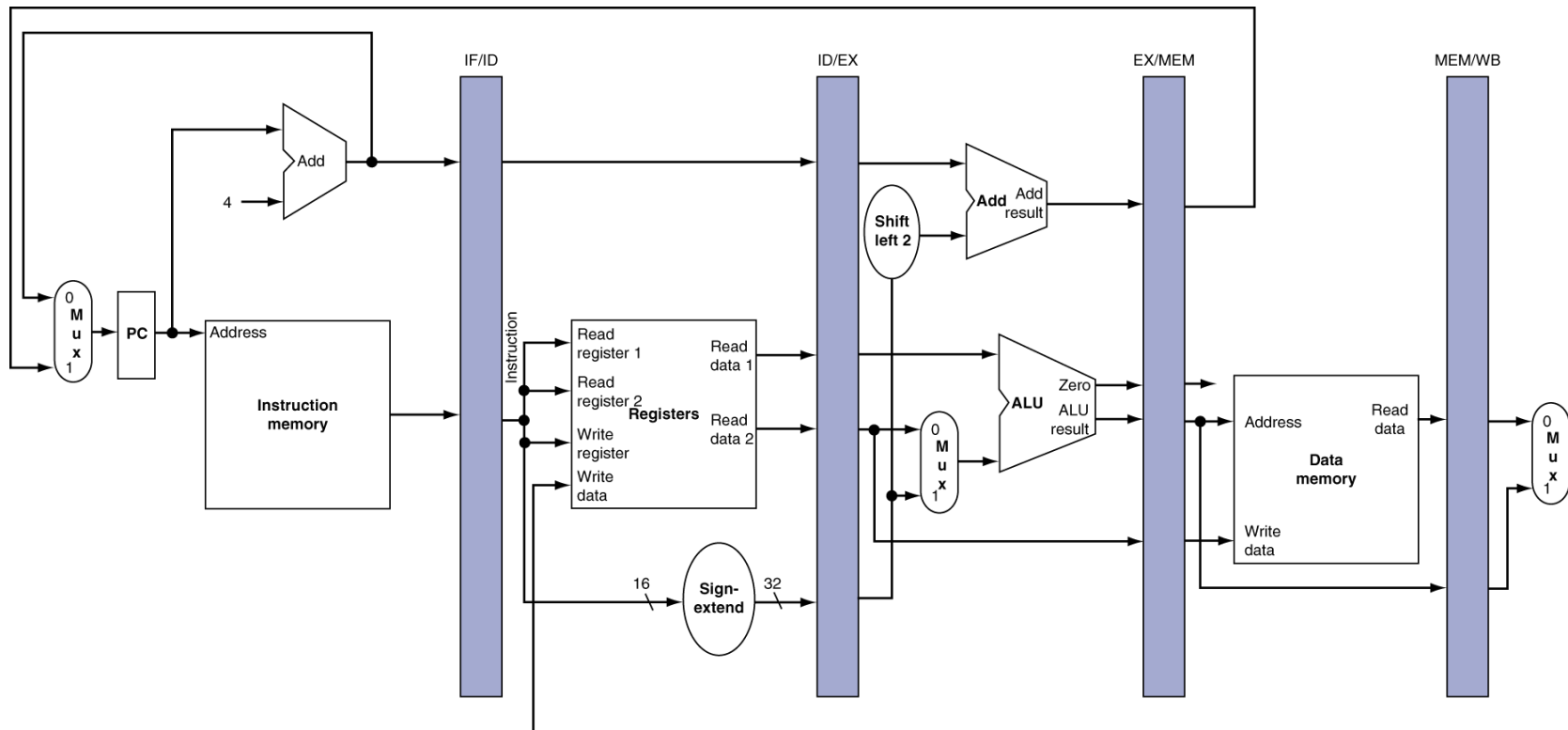

IF for Load, Store, ...

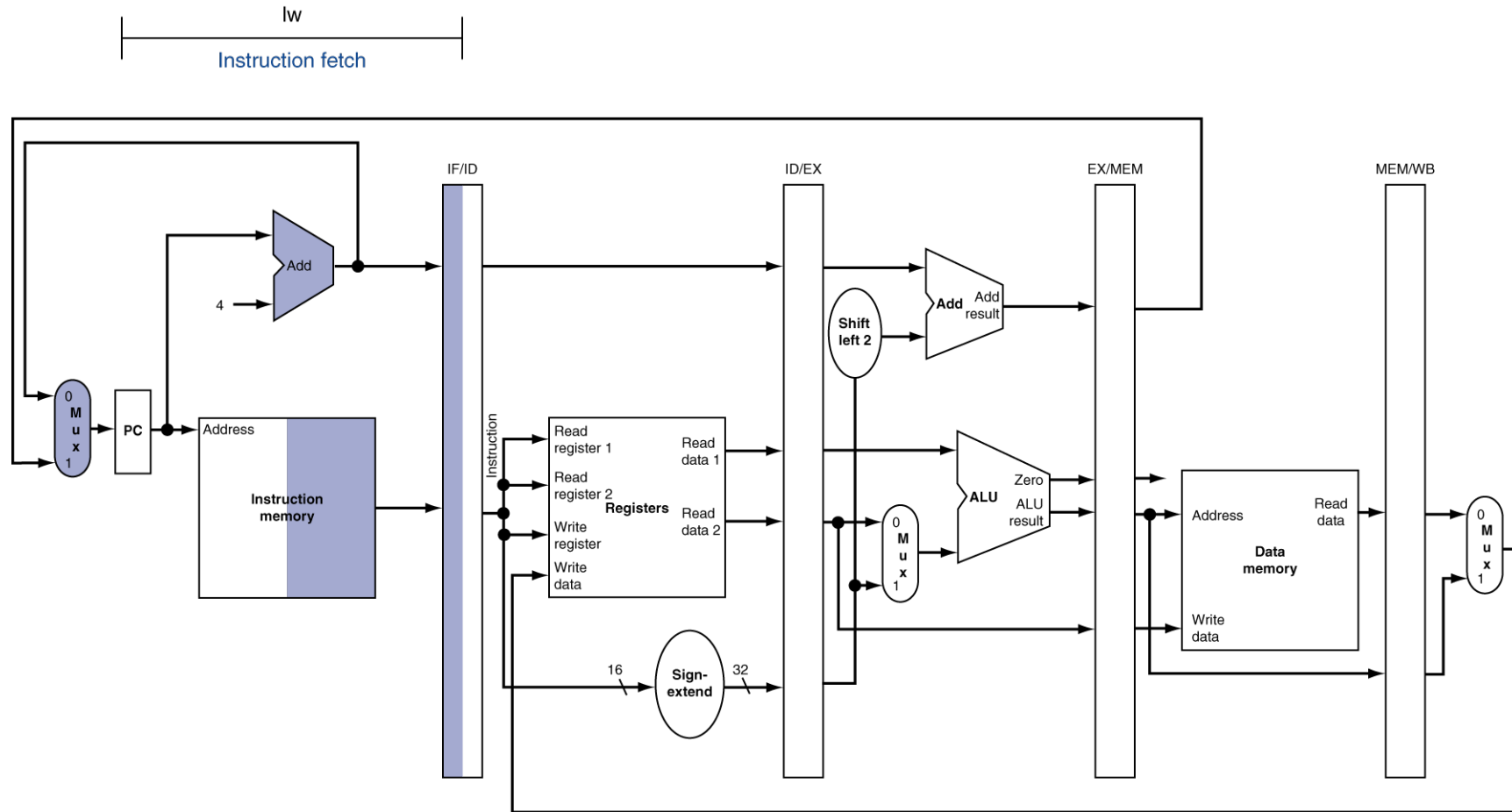

ID for Load, Store, ...

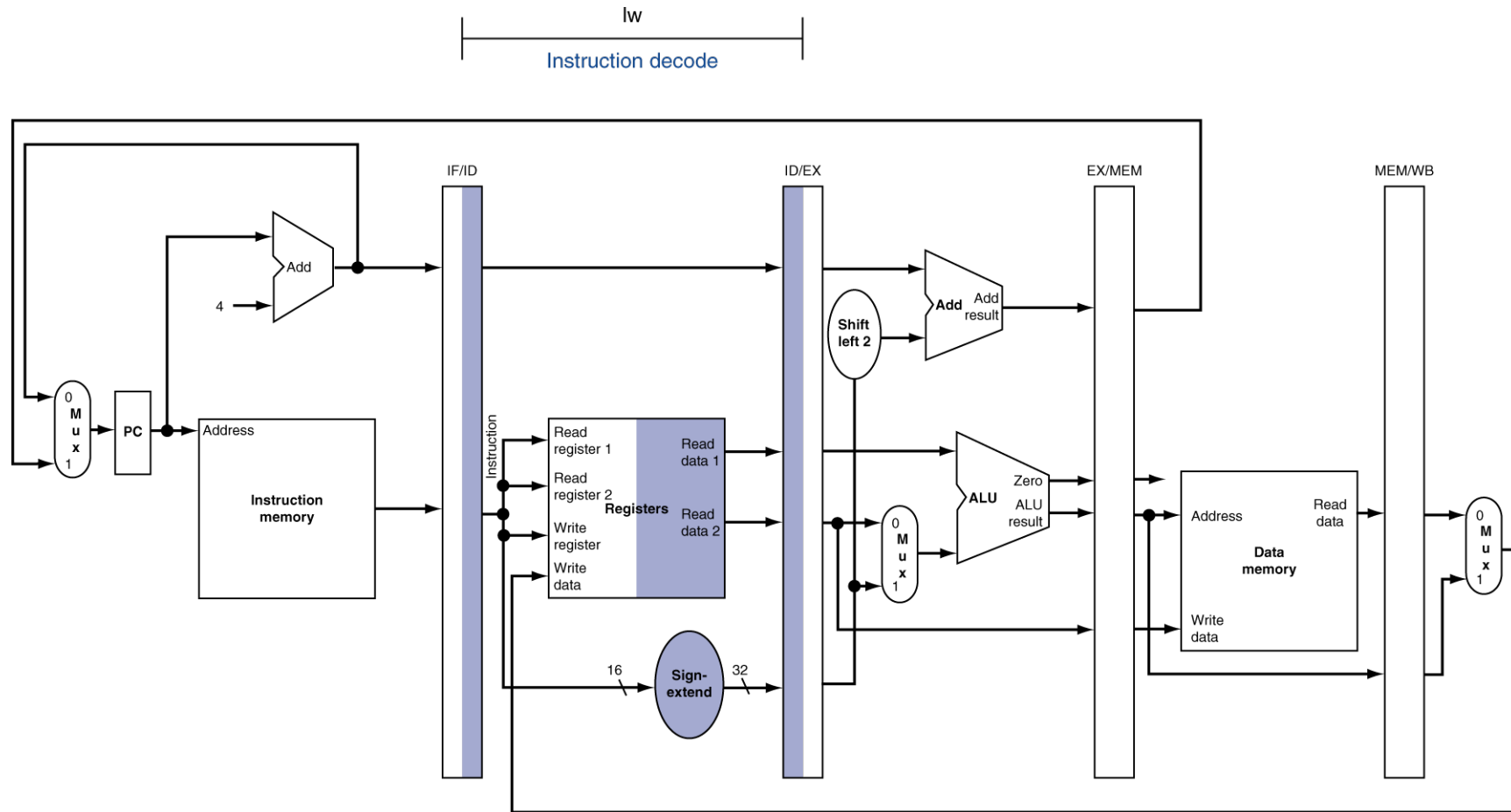

The register file will output data from both read registers, but load will only use one of them. We should

- A. Save both of them in ID/EX
- B. Only save the one we will use in ID/EX
- C. Do something else

EX for Load

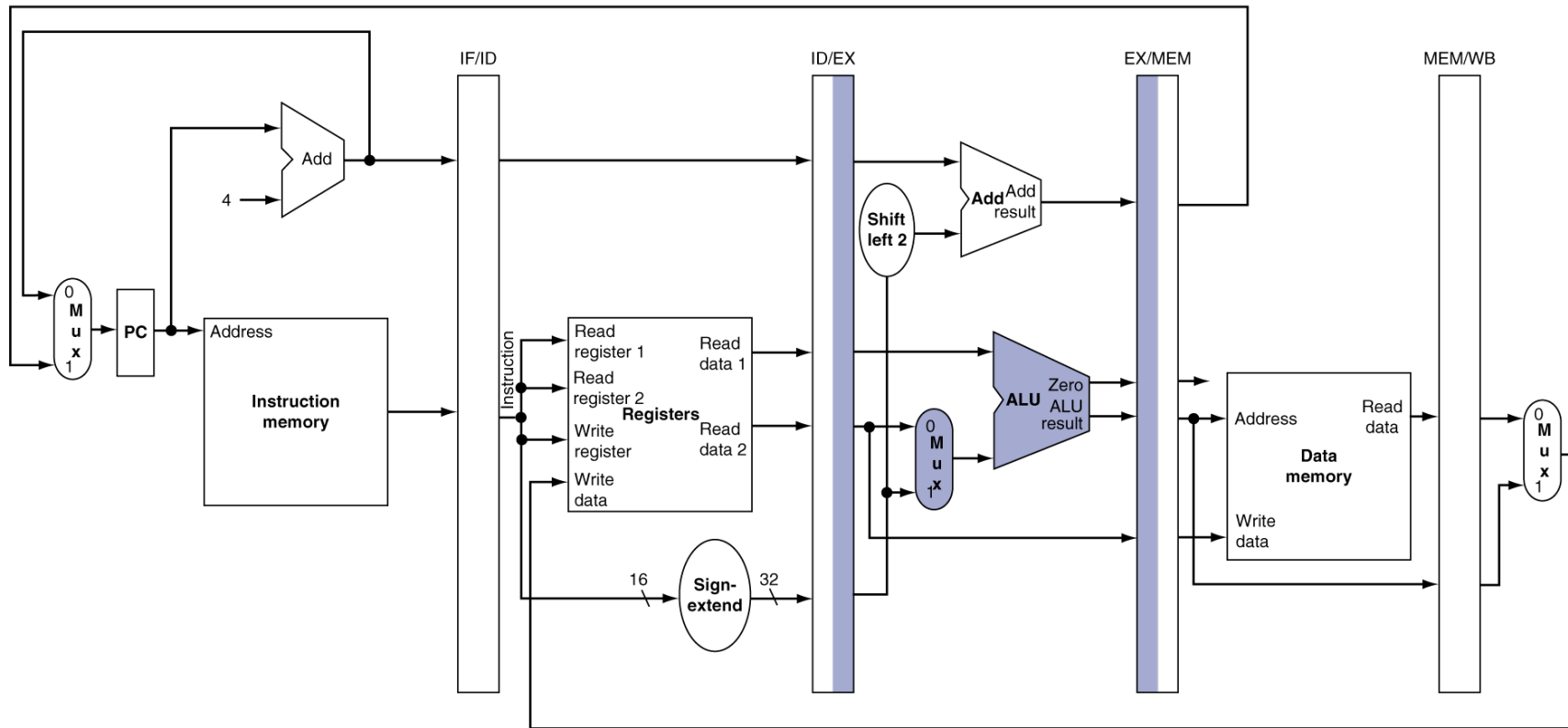

MEM for Load

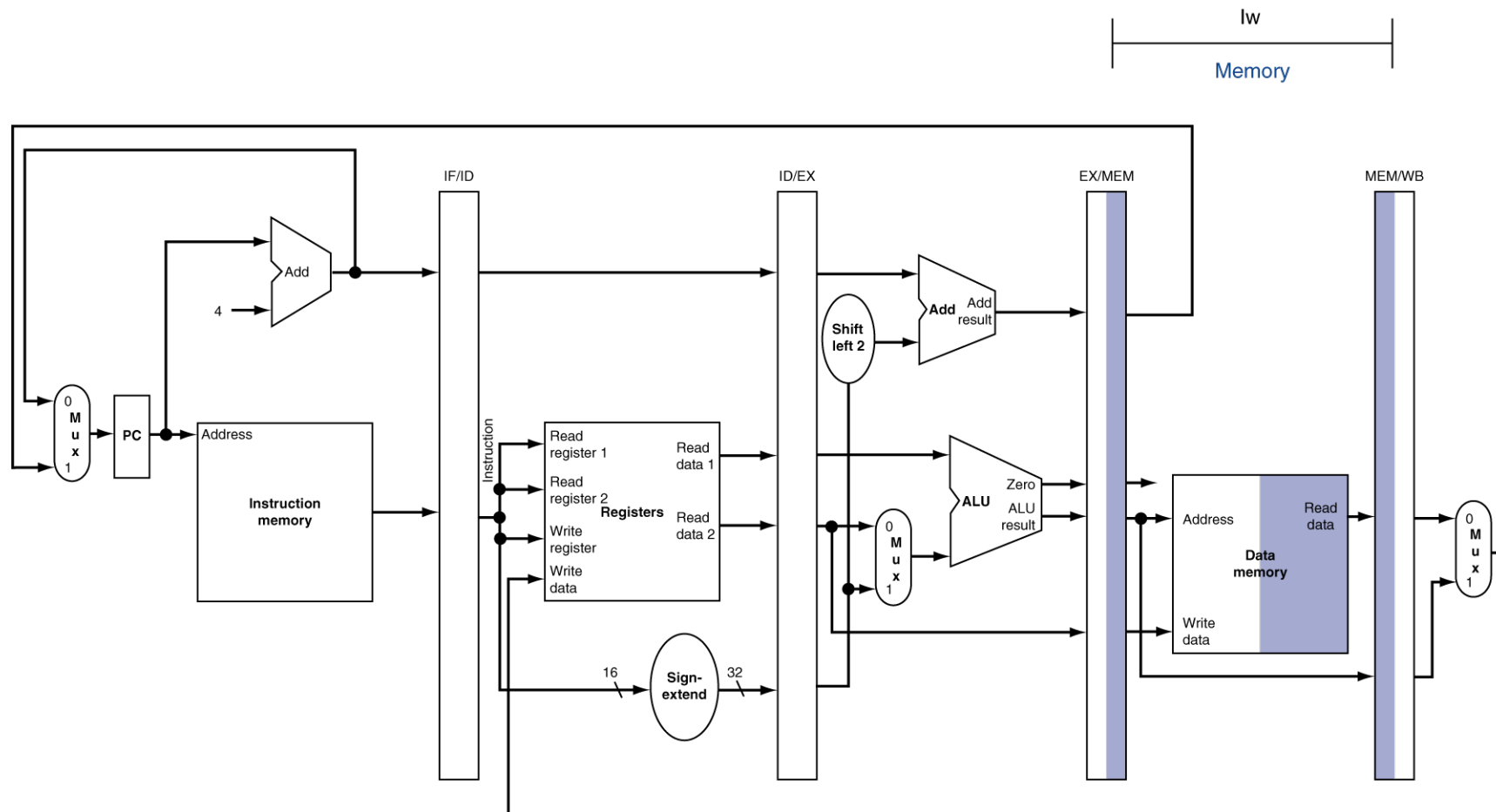

When we do WB for load

- A. Everything will be fine
- B. The data to write to the register will be wrong
- C. The register number to write to will be wrong

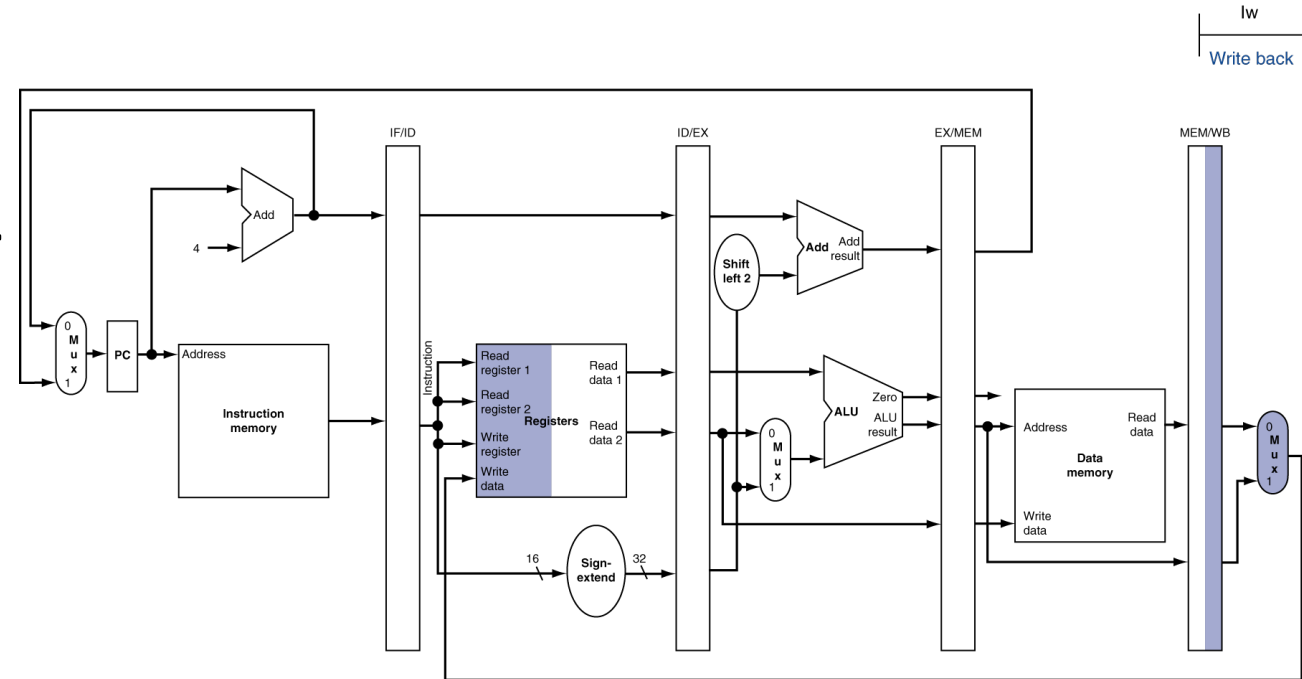

WB for Load

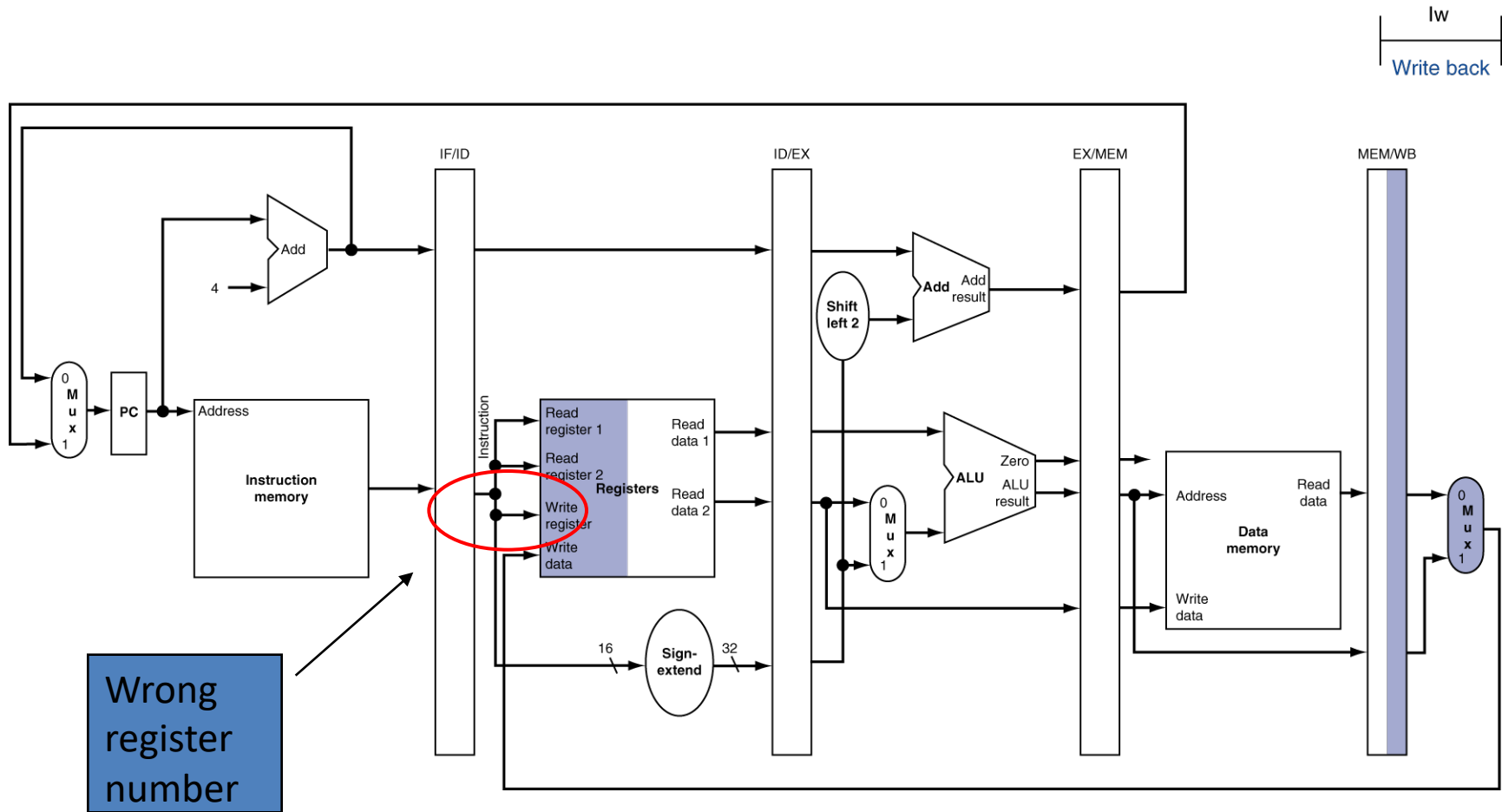

Corrected Datapath for Load

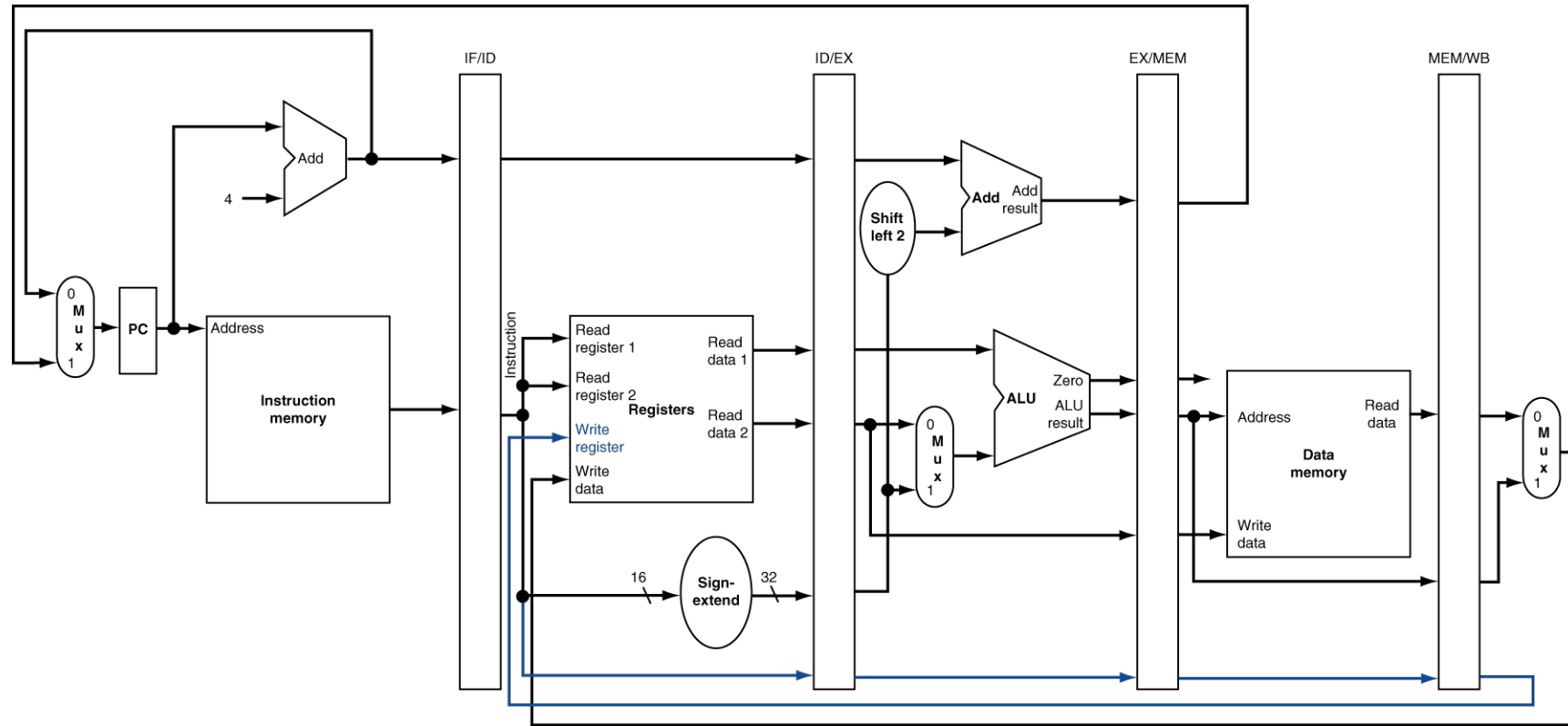

EX for Store

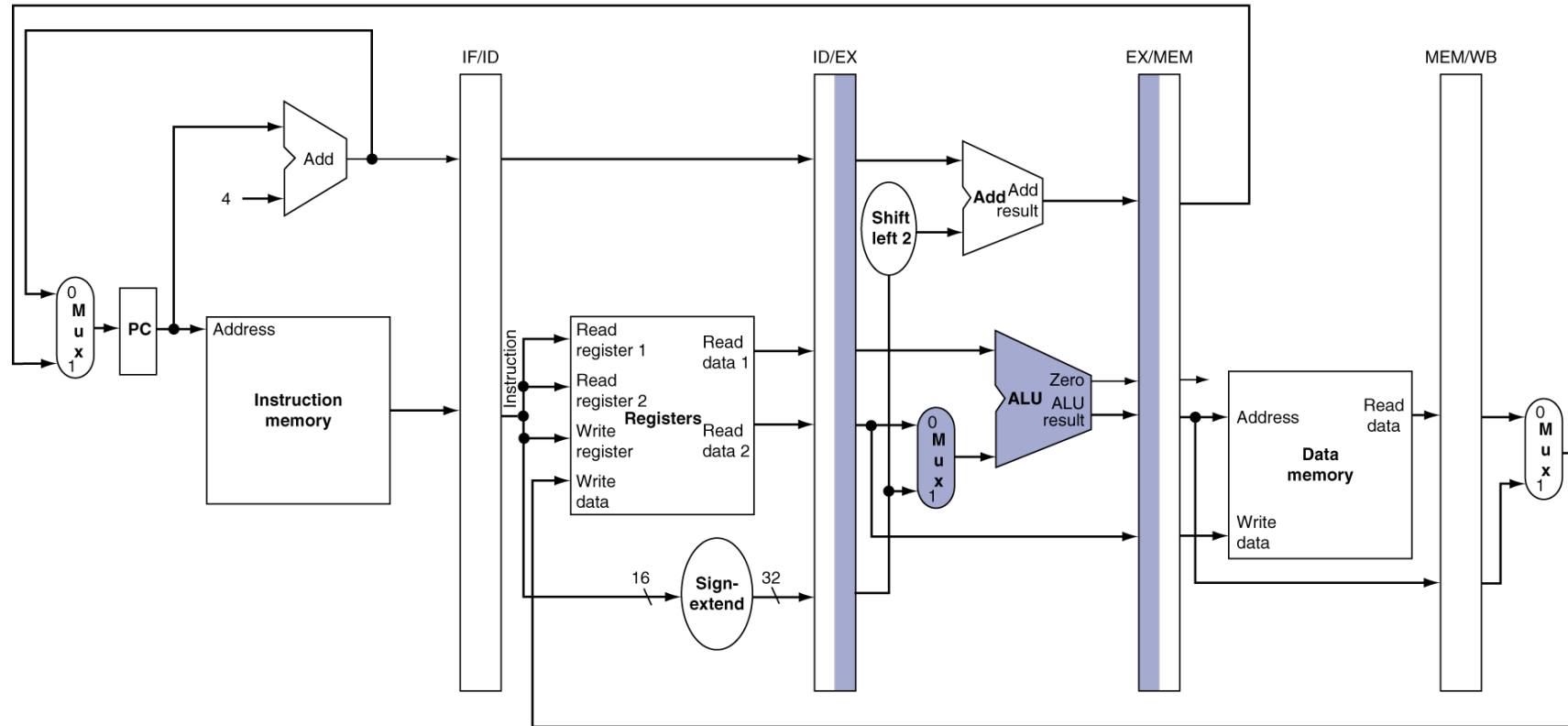

MEM for Store

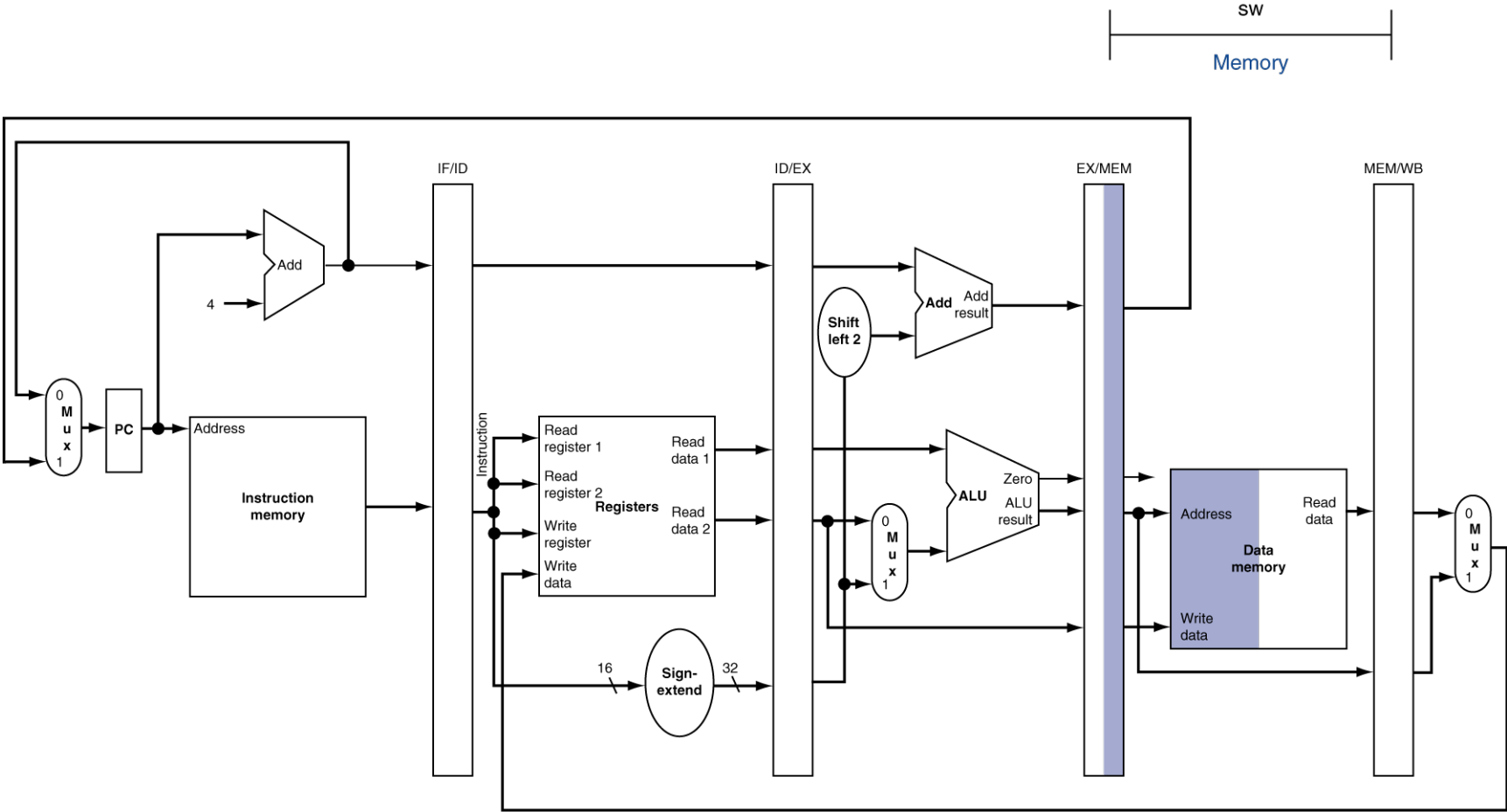

WB for Store

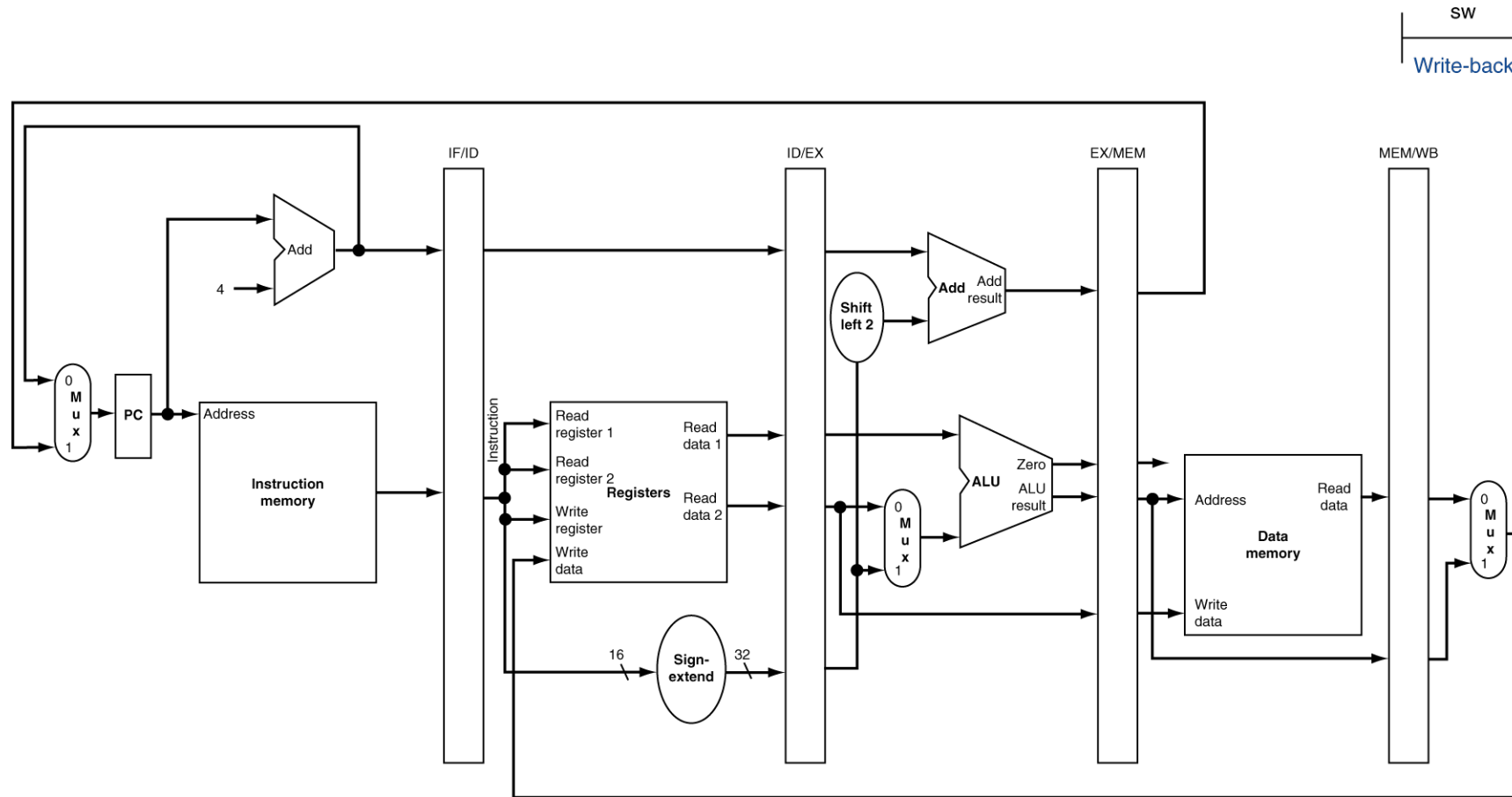

Reading

- Next lecture: Pipelined Datapath
 - Section 5.7
- Problem Set 10 due Friday
- Lab 8 due Monday